

VINTAGE CAST STONE ARCHITECTURAL PRE-CAST PRODUCT CATALOG

Lic. 1143020
(805) 889-1208
WWW.VINTAGECASTSTONE.COM

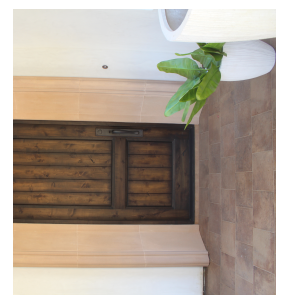

To our valued partners and future clients,

My name is Ali Raygoza, and as the owner of **Vintage Cast Stone**, I want to personally share who we are, what we stand for, and why our work means so much to us. Vintage Cast Stone is a family-owned and operated company built on more than two decades of hands-on experience in architectural cast stone production. After spending 21 years leading manufacturing operations, I founded this business in 2015 with a simple goal: to carry forward a legacy of precision mold-making, craftsmanship, and dependable service. Today, our team is based in Ventura, California, where our seasoned artisans and mold makers continue to be recognized for their meticulous attention to detail — a standard that has earned the trust of top contractors, architects, and stone suppliers throughout the region.

By inheriting an extensive mold library and long-standing manufacturing systems, we're able to offer our clients a virtually limitless design catalog, consistent quality, and efficient turnaround times. While our foundation is rooted in tradition, our approach is continuously evolving.

Blending Craftsmanship with Modern Fabrication

I believe great architecture deserves great execution. That's why we combine old-world craftsmanship with modern production methods to meet the needs of today's designers and builders. Our process includes:

- Digital modeling and CAD-to-mold workflows for precise dimensional accuracy
- CNC and 3D-printed mold components for complex geometry and rapid prototyping
- High-performance cast stone mixes engineered for strength and fine architectural detail
- Rigorous quality control systems to ensure uniform color, texture, and long-term durability

These innovations enable us to create intricate façades, custom precast elements, and restorative masonry with exceptional fidelity to every design.

Our Commitment to Responsible Manufacturing

Craftsmanship also means responsibility — to our clients, our community, and our environment. We continually refine our processes to reduce environmental impact by:

- Using locally sourced aggregates and low-carbon cement alternatives where appropriate
- Recycling water and materials to minimize waste
- Utilizing energy-efficient curing methods that improve performance while lowering energy use
- Designing long-lasting architectural components that reduce long-term environmental cost

For us, sustainability isn't an add-on; it's simply part of doing things the right way.

Integrity, Collaboration, and Pride in Every Project

Whether we're supporting a historic restoration or fabricating a cutting-edge architectural feature, we approach every project with respect for structural integrity, design intent, and the craft itself. Our team excels at solving complex challenges and transforming advanced concepts into buildable, lasting reality.

We work closely with architects, engineers, builders, and designers to bring drawings to life with precision and care. And when challenges arise — as they always do in construction — you can count on us to meet them with skill, ingenuity, and zero shortcuts.

With Vintage Cast Stone, you're not just receiving cast stone products; you're receiving decades of experience, innovation, and pride poured into every mold, panel, and component we produce.

Thank you for considering us for your next project. It would be our honor to collaborate with you.

Warm regards,
Ali Raygoza
Owner, Vintage Cast Stone

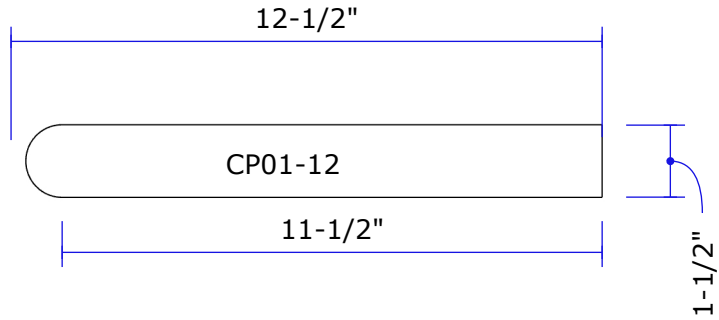
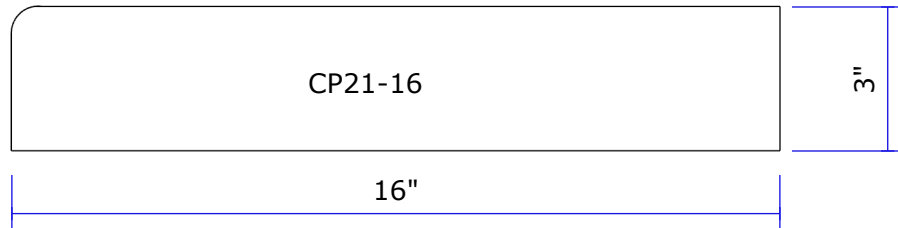
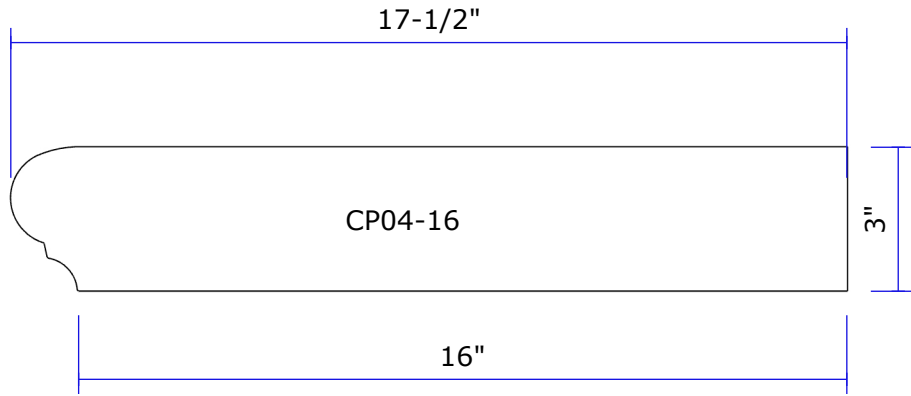

**POOL COPING
&
STEP THREAD**

SCALE: 1-1/2" = 1'

**VINTAGE CAST STONE
ARCHITECTURAL PRE-CAST**
LIC.# 1143020

**DRAWN BY: AR
11/25**

SOME RIGHTS RESERVED ©
(805) 889-1208
INFO@VINTAGECASTSTONE.COM

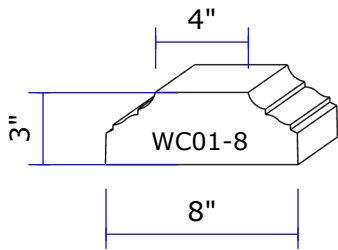

Also available in 12.75",
14", 18" and 20" widths
11"

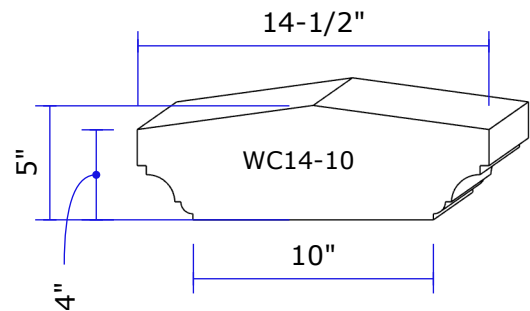
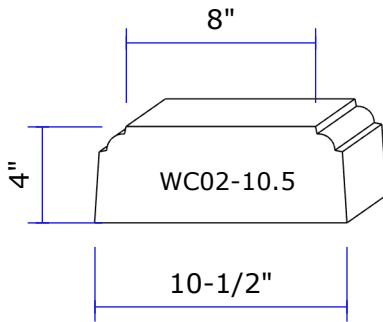
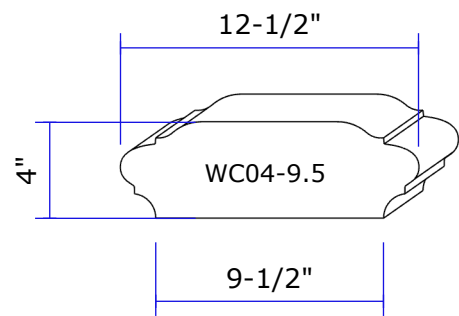
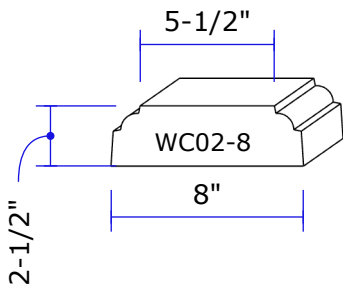
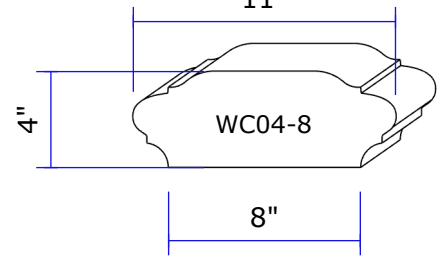

Also available in 10"
and 14" widths

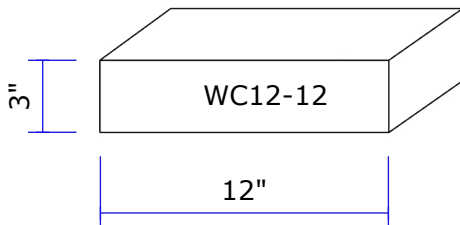

WALL CAPS

SCALE: 1-1/2" = 1'

**VINTAGE CAST STONE
ARCHITECTURAL PRE-CAST**

LIC.# 1143020

**DRAWN BY: AR
11/25**

SOME RIGHTS RESERVED ©
(805) 889-1208
INFO@VINTAGECASTSTONE.COM

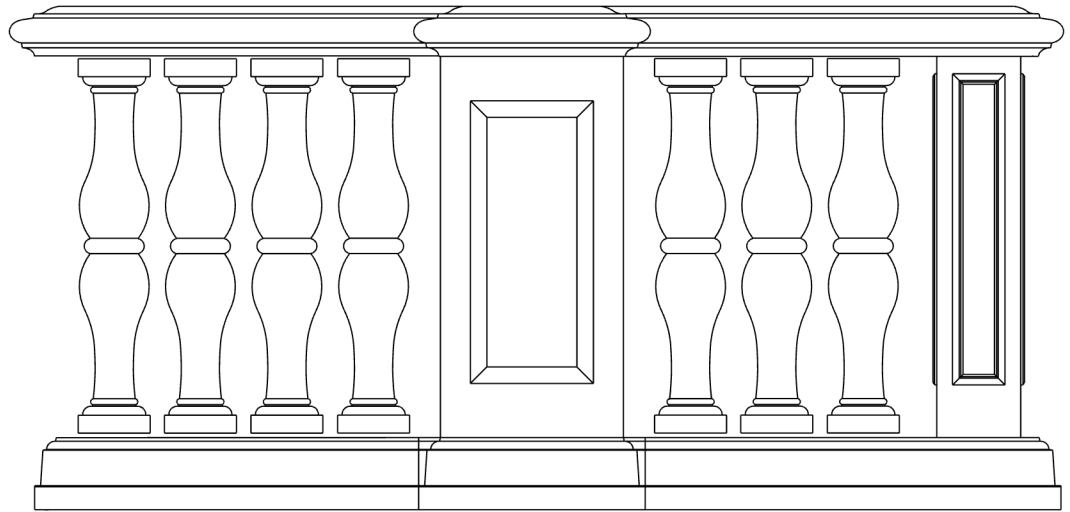
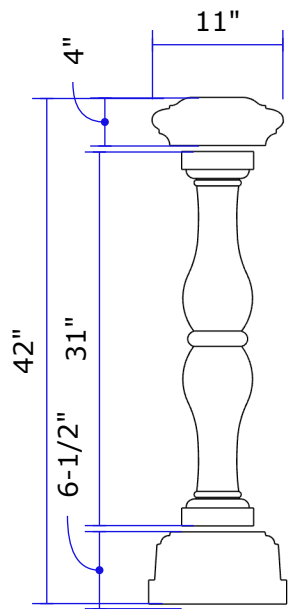

11-1/2"

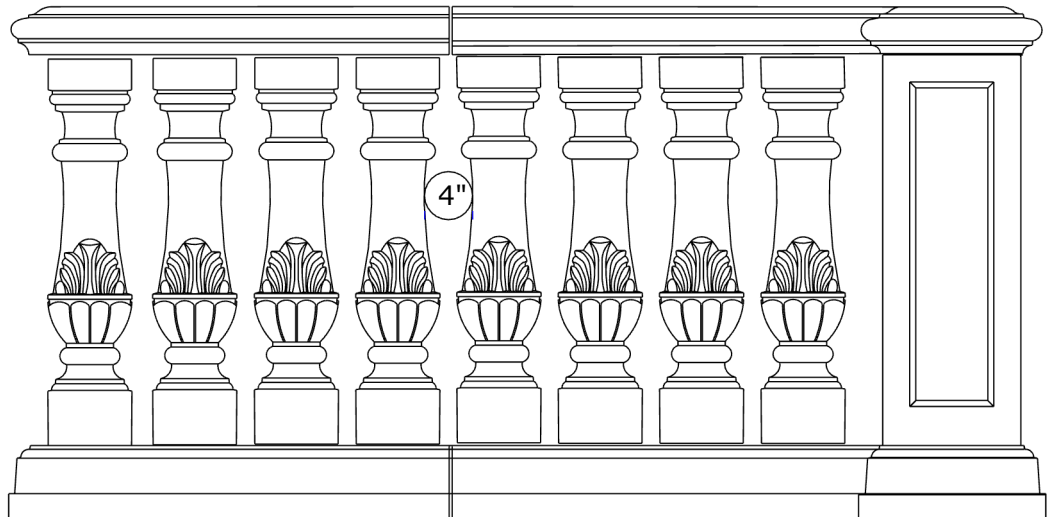
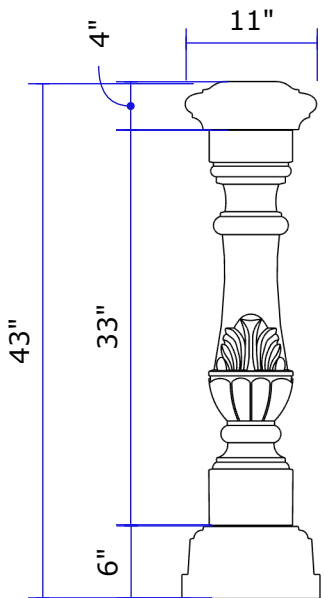

11-1/2"

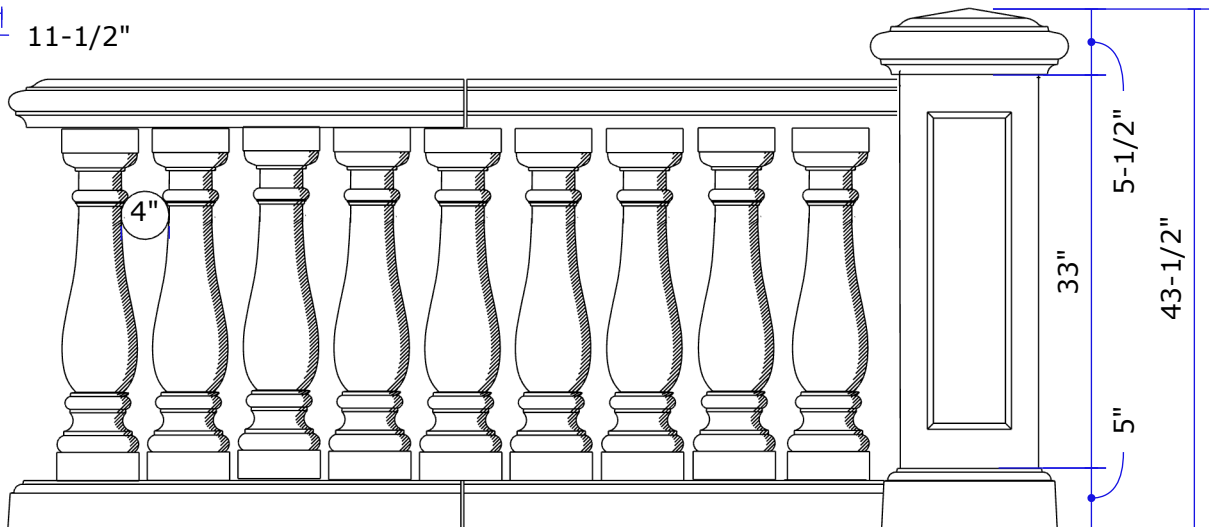
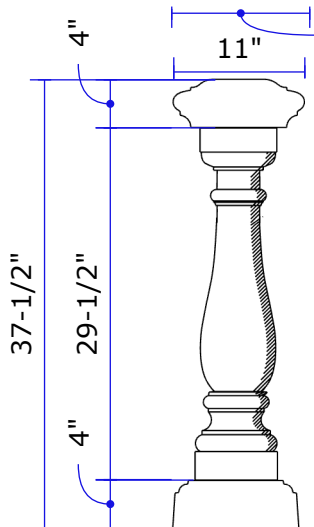

10-1/2"

BALUSTRADE

SCALE: 3/4" = 1'

**VINTAGE CAST STONE
ARCHITECTURAL PRE-CAST**

LIC.# 1143020

**DRAWN BY: AR
11/25**

SOME RIGHTS RESERVED ©
(805) 889-1208
INFO@VINTAGECASTSTONE.COM

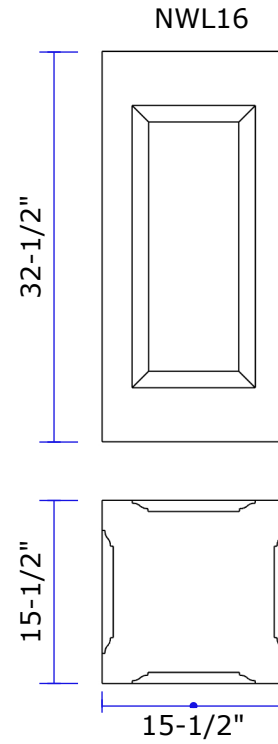
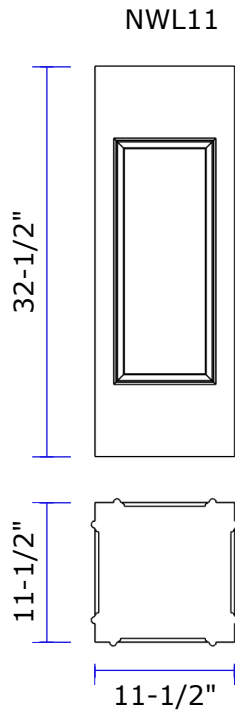
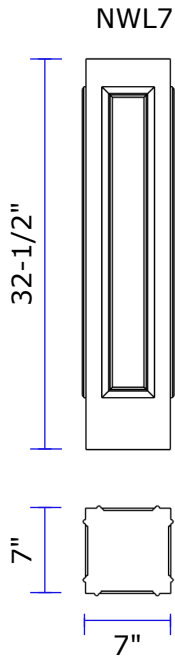
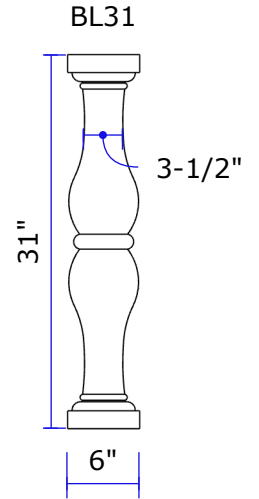
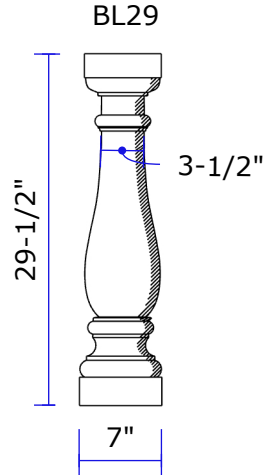
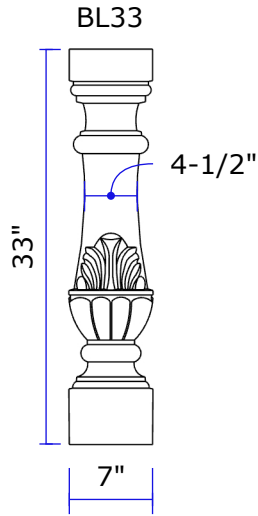
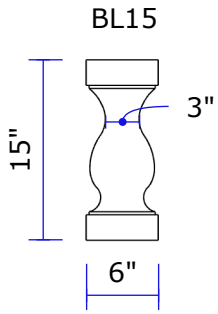

**BALUSTERS
&
NEWEL POSTS**
SCALE: 3/4" = 1'

**VINTAGE CAST STONE
ARCHITECTURAL PRE-CAST**
LIC.# 1143020

DRAWN BY: AR
11/25
SOME RIGHTS RESERVED ©
(805) 889-1208
INFO@VINTAGECASTSTONE.COM

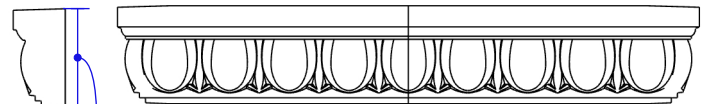
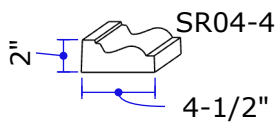
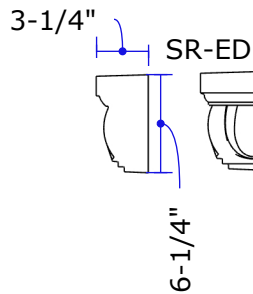
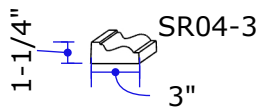
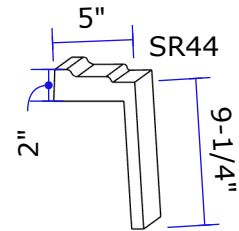
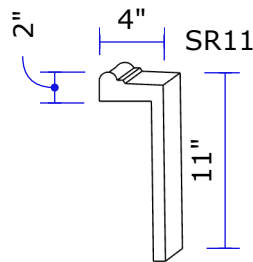
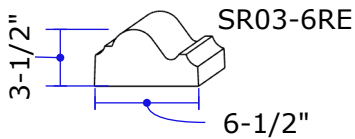
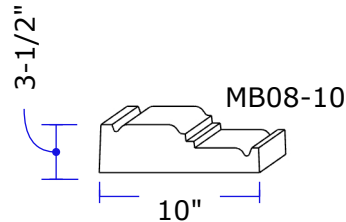
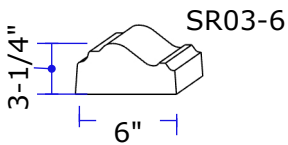
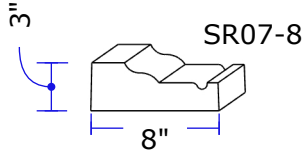
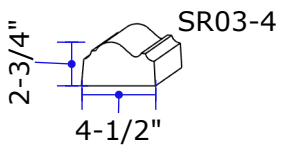
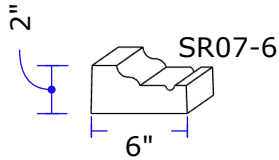
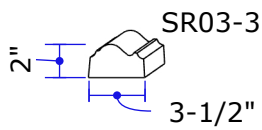
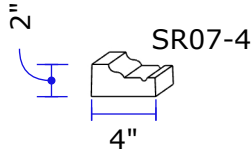
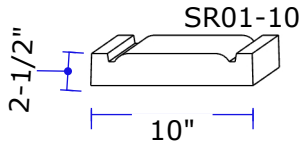
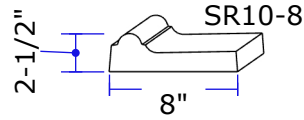
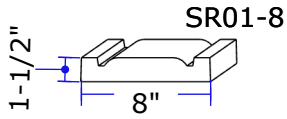
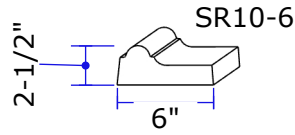
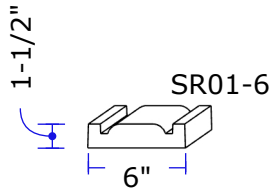

TRIM AND MOLDINGS

SCALE: 1" = 1'

**VINTAGE CAST STONE
ARCHITECTURAL PRE-CAST**
LIC.# 1143020

DRAWN BY: AR
11/25
SOME RIGHTS RESERVED ©
(805) 889-1208
INFO@VINTAGECASTSTONE.COM

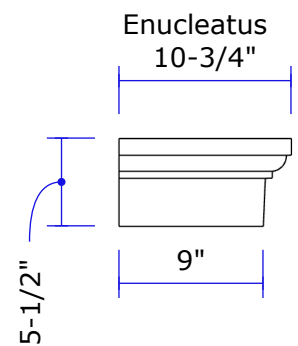
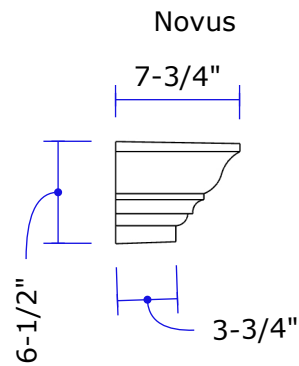
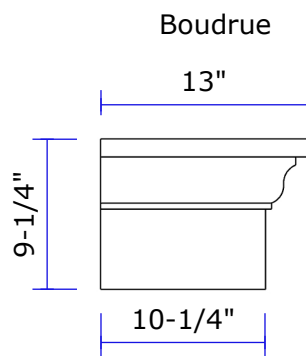
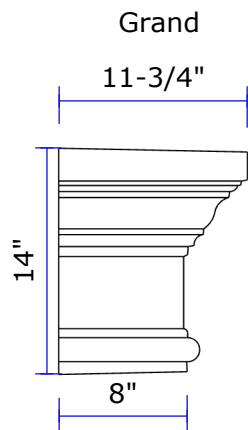
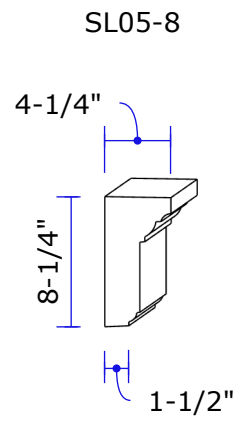
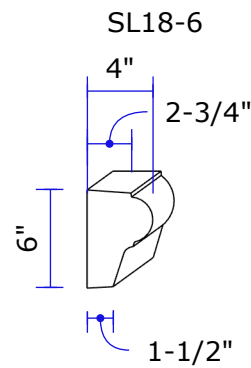
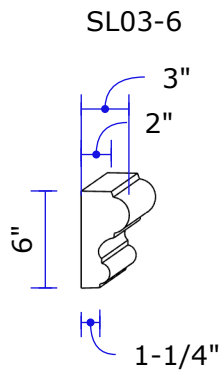
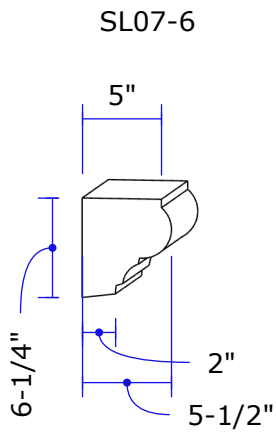
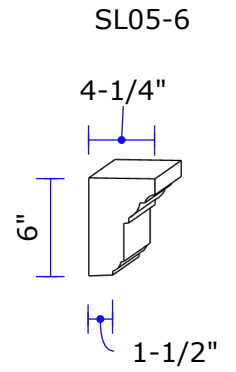
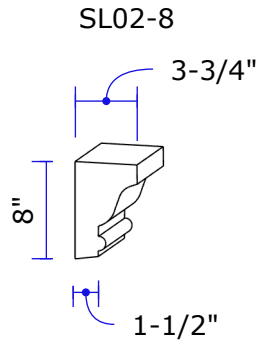
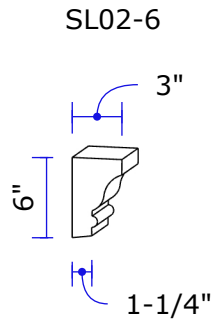
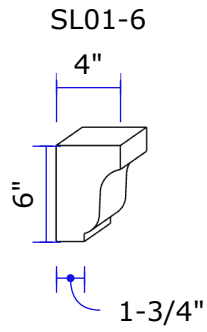

SILLS AND MANTELS

SCALE: 1" = 1'

**VINTAGE CAST STONE
ARCHITECTURAL PRE-CAST**
LIC.# 1143020

DRAWN BY: AR
11/25
SOME RIGHTS RESERVED ©
(805) 889-1208
INFO@VINTAGECASTSTONE.COM

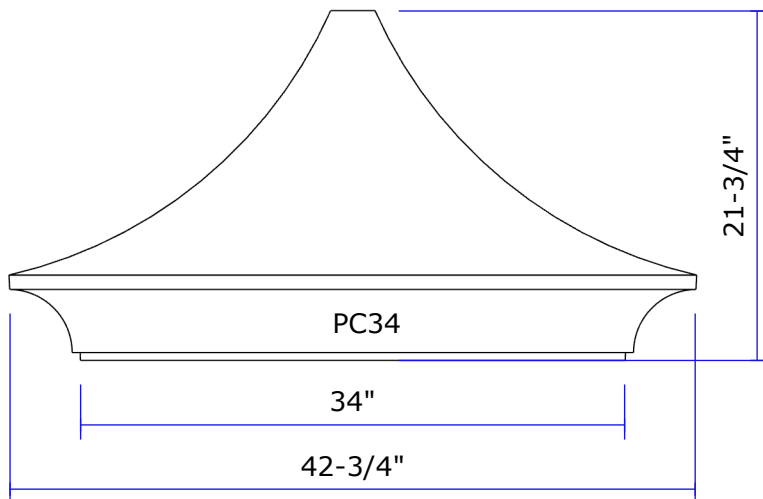
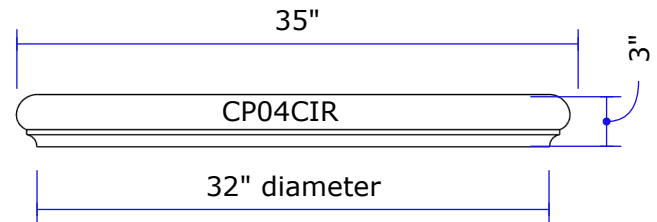
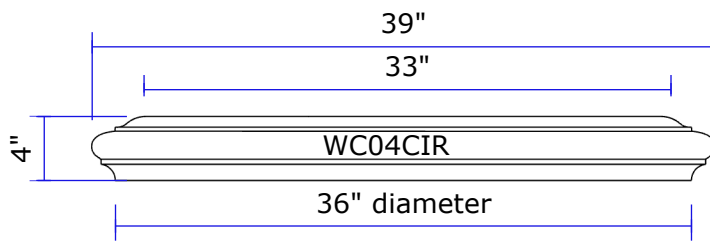
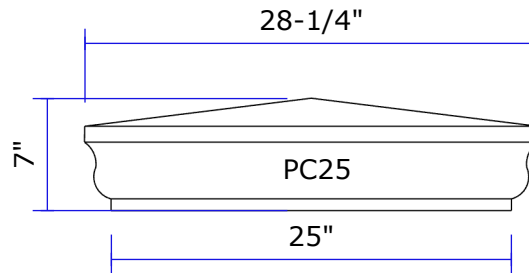
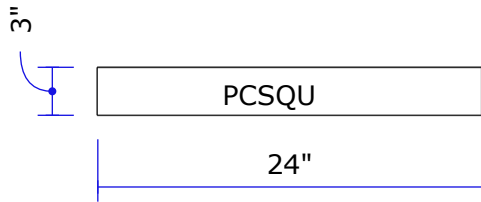
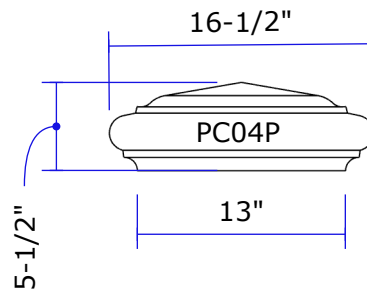
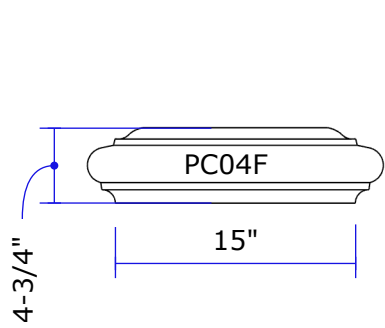

**PC04F, PC04P & PCSQU
available in different sizes
inquire for dimensions**

PILASTER CAPS

SCALE: 1" = 1'

**VINTAGE CAST STONE
ARCHITECTURAL PRE-CAST**
LIC.# 1143020

DRAWN BY: AR
11/25
SOME RIGHTS RESERVED ©
(805) 889-1208
INFO@VINTAGECASTSTONE.COM

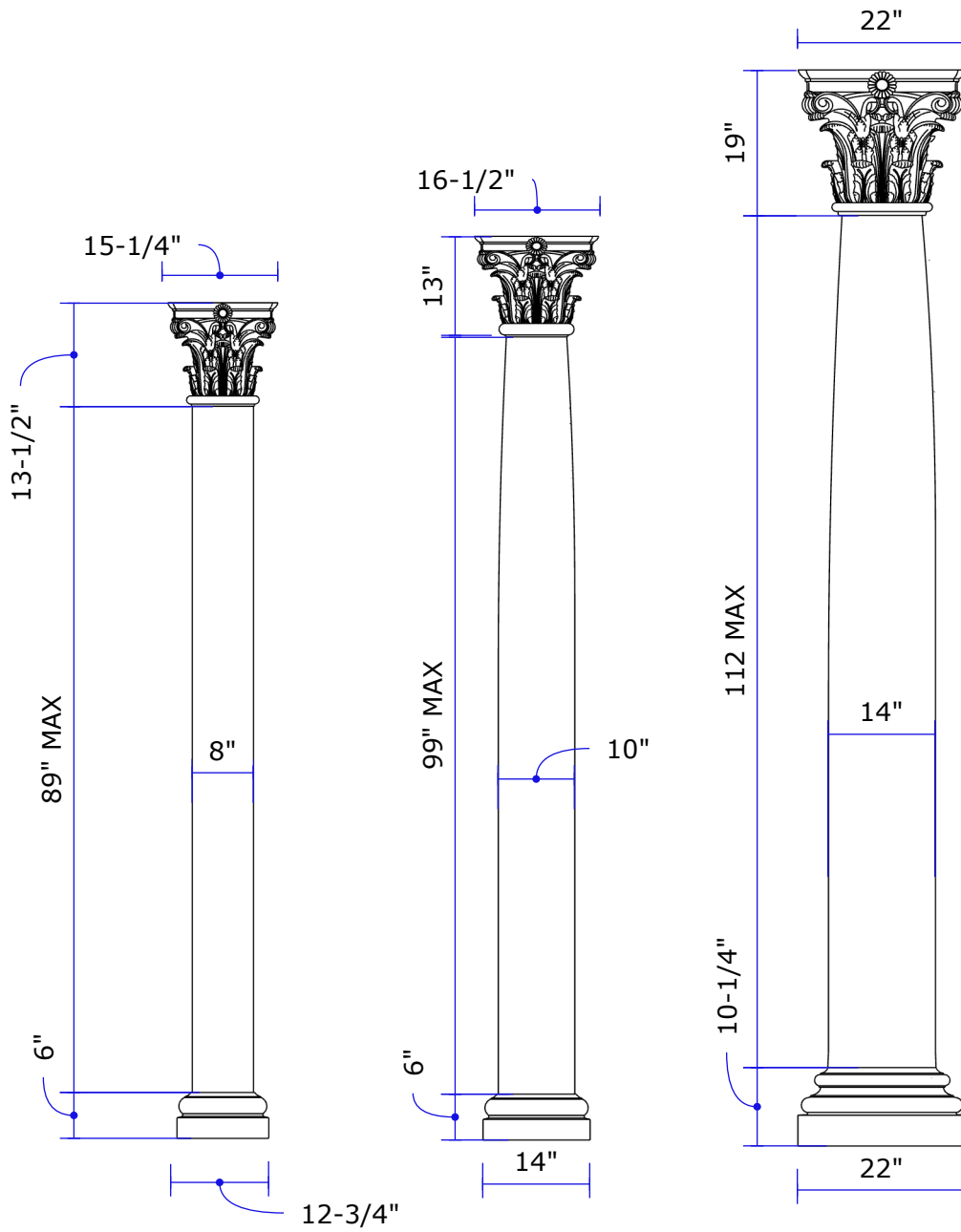

CORINTHIAN COLUMNS

SCALE: 1/2" = 1'

**VINTAGE CAST STONE
ARCHITECTURAL PRE-CAST**

LIC.# 1143020

**DRAWN BY: AR
11/25**

SOME RIGHTS RESERVED ©
(805) 889-1208
INFO@VINTAGECASTSTONE.COM

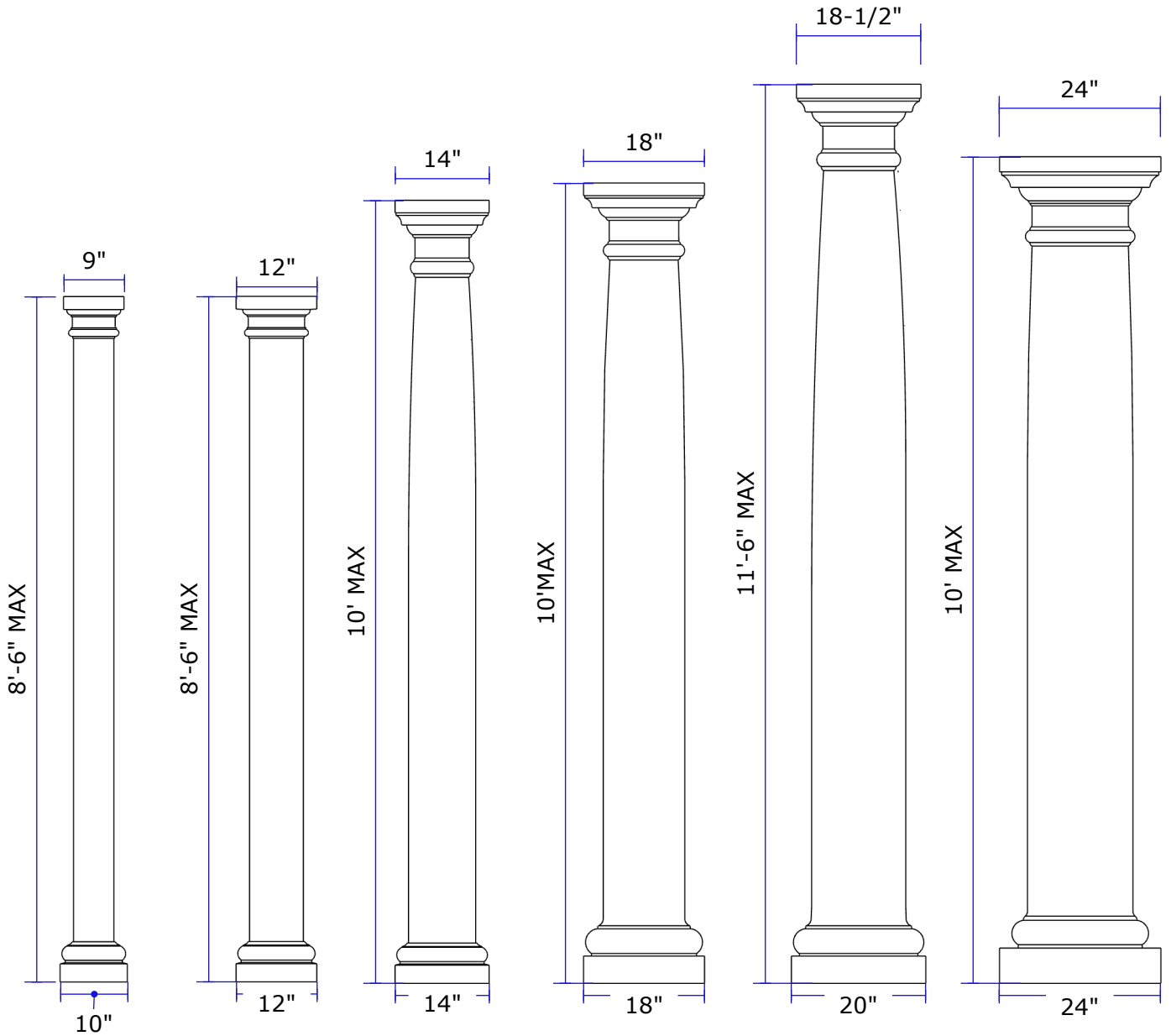

**4 PIECE TUSCAN COLUMNS
ADJUSTABLE HEIGHT**

SCALE: 1/2" = 1'

**VINTAGE CAST STONE
ARCHITECTURAL PRE-CAST**

LIC.# 1143020

**DRAWN BY: AR
11/25**

SOME RIGHTS RESERVED ©
(805) 889-1208
INFO@VINTAGECASTSTONE.COM

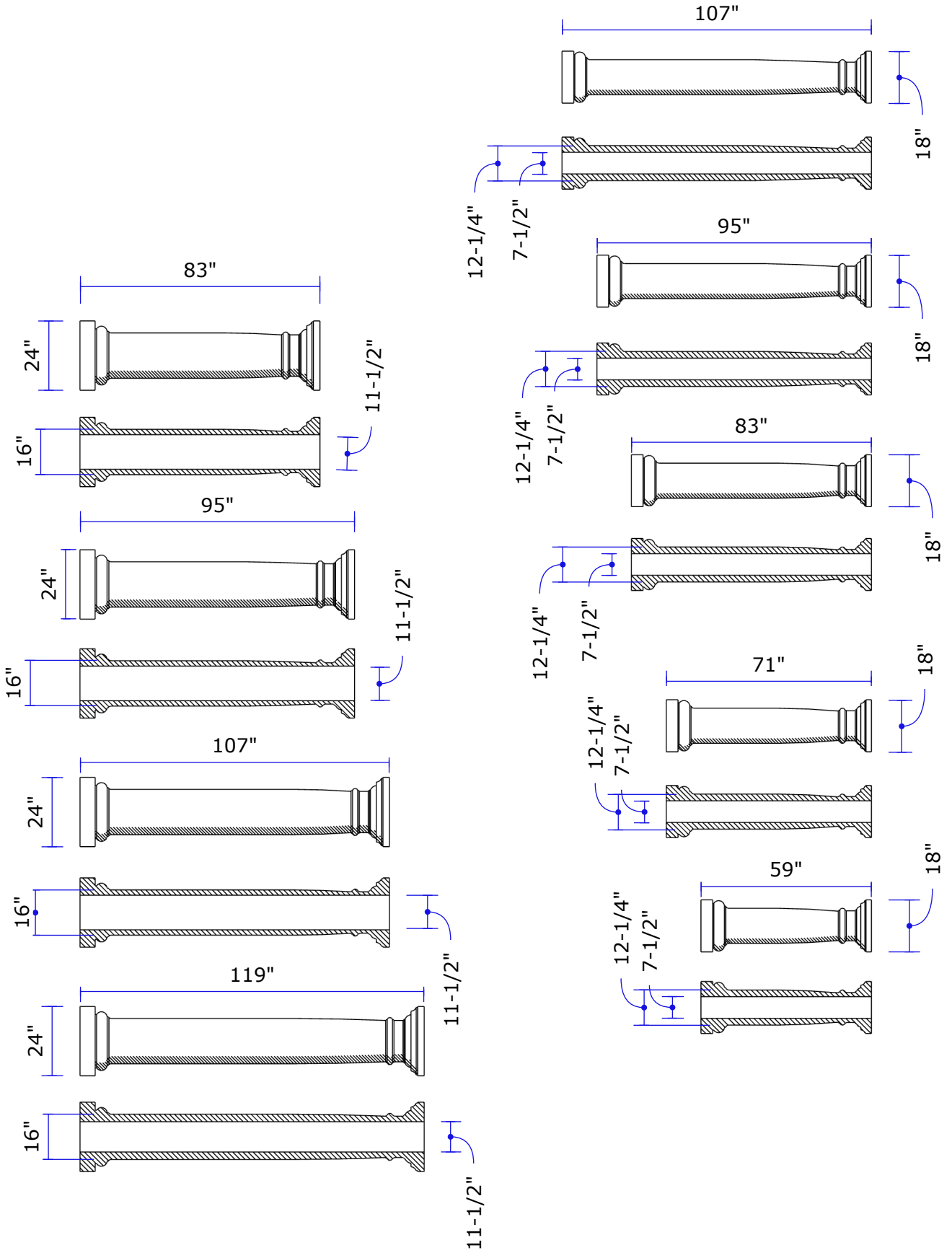

2 PIECE TUSCAN COLUMNS

SCALE: 1/4" = 1'

**VINTAGE CAST STONE
ARCHITECTURAL PRE-CAST**

LIC.# 1143020

**DRAWN BY: AR
11/25**

SOME RIGHTS RESERVED ©
(805) 889-1208
INFO@VINTAGECASTSTONE.COM

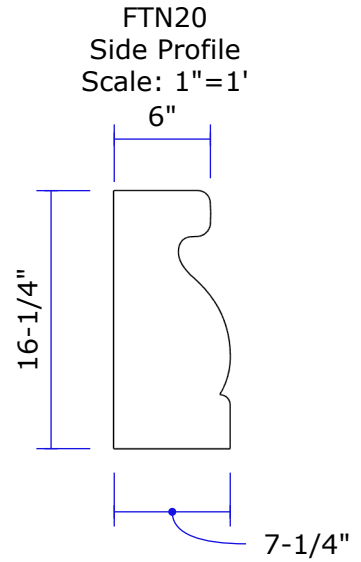
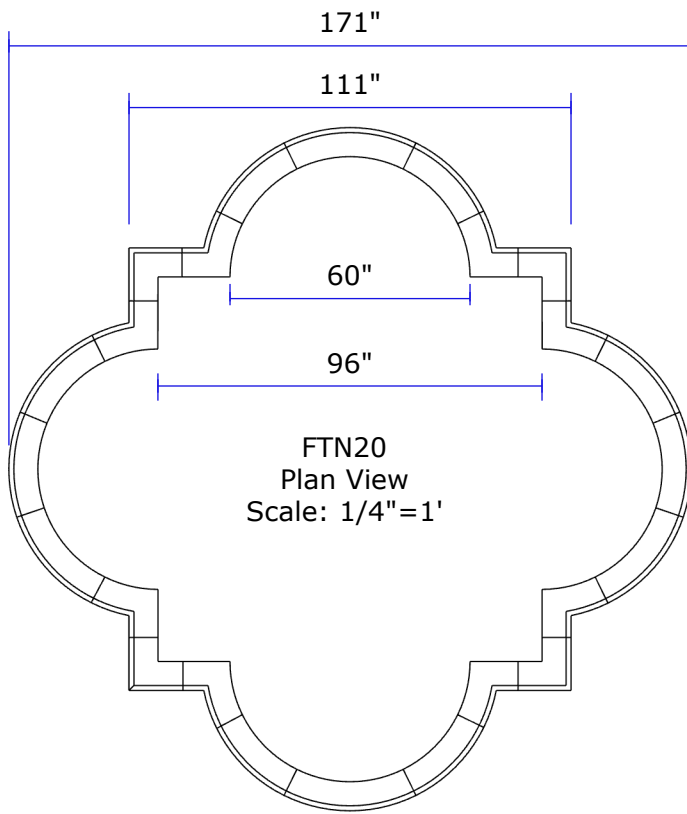

FTN10-ED
Side Profile
Scale: 1"=1'

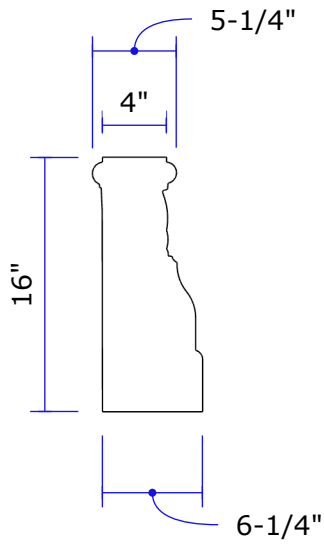

FTN10-ED
Front View: Egg and Dart
Scale=1"=1'

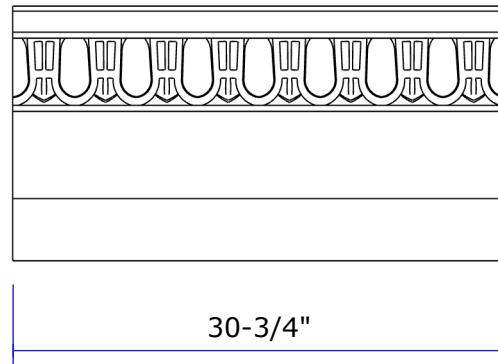

FOUNTAIN BASINS

SCALE:

**VINTAGE CAST STONE
ARCHITECTURAL PRE-CAST**

LIC.# 1143020

**DRAWN BY: AR
11/25**

SOME RIGHTS RESERVED ©
(805) 889-1208
INFO@VINTAGECASTSTONE.COM

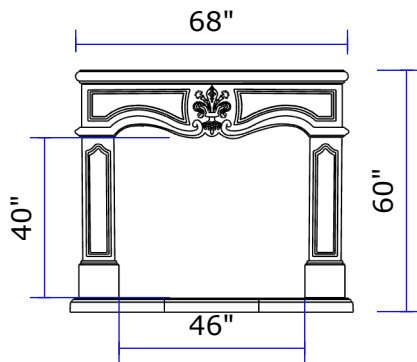
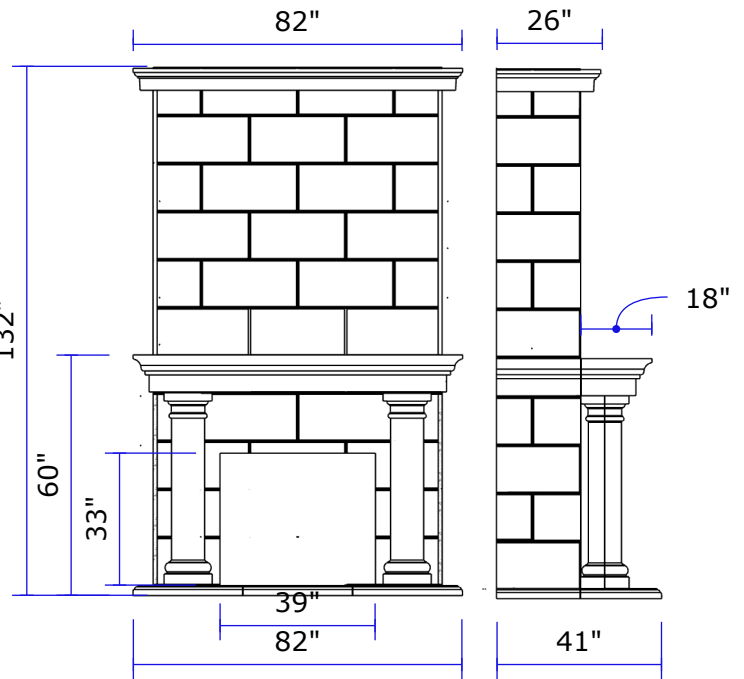
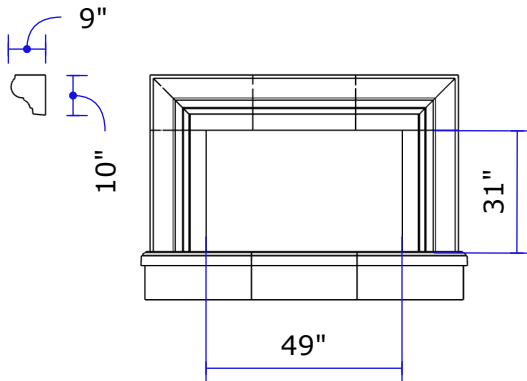
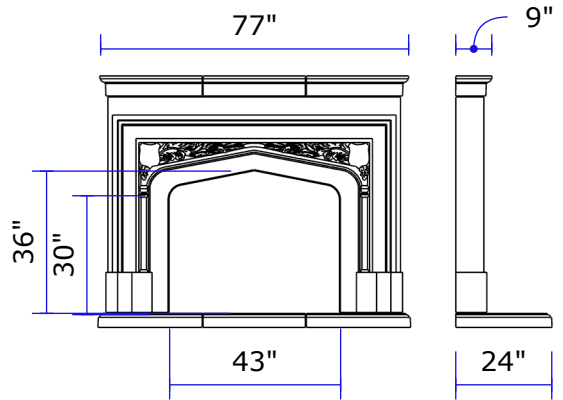
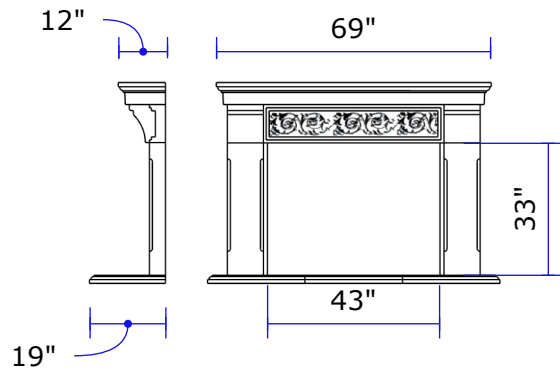
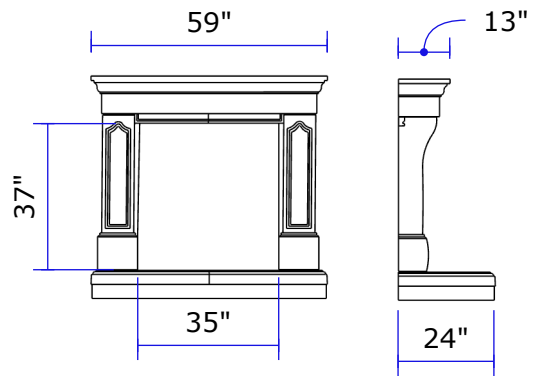
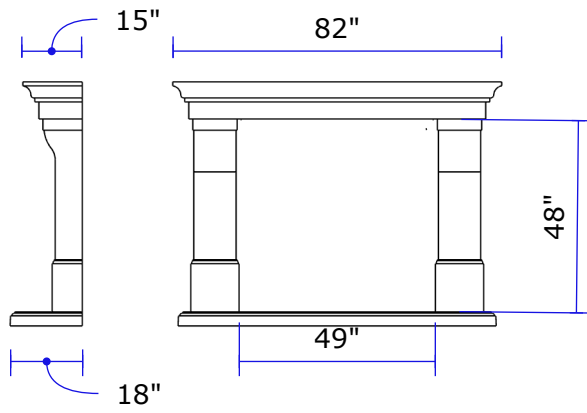

FIREPLACE SURROUNDS

SCALE: 1/4" = 1'

**VINTAGE CAST STONE
ARCHITECTURAL PRE-CAST**
LIC.# 1143020

**DRAWN BY: AR
11/25**

SOME RIGHTS RESERVED ©
(805) 889-1208
INFO@VINTAGECASTSTONE.COM





We offer a curated range of cast stone textures and colors to complement any architectural style. Textures include Smooth/Honed for a refined modern look, Antique/Distressed for added character, Split-Face and Rock-Face for a rugged natural feel, Chiseled/Tooled for traditional detailing, Burnished for a subtle polished sheen, Acid-Wash for lightly exposed aggregates, and fully Custom Textures to match existing stonework. Our integrally colored cast stone comes in a versatile palette of light neutrals such as White, Cream, Buff, and Sandstone; a range of grays from Light Gray to Graphite and Charcoal; warm earth tones like Driftwood, Fawn, Brownstone, and Straw; and bold accent options including Terracotta, deep reds, greens, or custom color matches. With color running through the material and textures that shape how light interacts with each surface, our cast stone provides long-lasting beauty and tailored design flexibility for any project.

